

FIBERER 8.5Gbps 300m SFP+ Optical Transceiver FPP-858G-SRC

Features

- ◆ Optical interface compliant to IEEE 802.3ae
- ◆ Electrical interface compliant to SFFPP-8431
- ◆ Hot Pluggable
- ◆ 850nm VCSEL transmitter, PIN photo-detector
- ◆ Maximum link length of 300m on 2000MHz/km MMF
- ◆ Low power consumption
- ◆ Maximum link length of 300m on 2000MHz/km MMF
- ◆ All-metal housing for superior EMI performance
- ◆ Advanced firmware allow customer system encryption information to be stored in transceiver
- ◆ Cost effective SFP+ solution, enables higher port densities and greater bandwidth
- ◆ Operating case temperature:
Standard : 0 to +70°C
Industrial : -40 to +85°C
- ◆ RoHS6 compliant (lead free) 



Applications

- ◆ Tri Rate 1.0625 / 2.125 / 4.25/8.5Gbp/s Fibre Channel
- ◆ Other optical links

Product description

This 850 nm VCSEL 8.5Gigabit SFP+ transceiver is designed to transmit and receive optical data over 50/125 μm or 62.5/125 μm multimode optical fiber (Table 1).

Fiber type	Minimum modal bandwidth @ 850 nm (MHz*km)	Operating range (meters)
62.5 μm MMF	160	2 to 26
	200	2 to 33
50 μm MMF	400	2 to 66
	500	2 to 82
	2000	2 to 300

Table 1: SFP+ SR Operating Range for each Optical Fiber Type

The SFP+ SR module electrical interface is compliant to SFI electrical specifications. The transmitter input and receiver output impedance is 100 Ohms differential. Data lines are internally AC coupled. The module provides differential termination and reduce differential to common mode conversion for quality signal termination and low EMI. SFI typically operates over 200 mm of improved FR4 material or up to about 150mm of standard FR4 with one connector.

The transmitter converts 8.5Gbit/s serial PECL or CML electrical data into serial optical data compliant with the FC standard. An open collector compatible Transmit Disable (Tx_Dis) is provided. A logic “1,” or no connection on this pin will disable the laser from transmitting. A logic “0” on this pin provides normal operation. The transmitter has an internal automatic power control loop (APC) to ensure constant optical power output across supply voltage and temperature variations. An open collector compatible Transmit Fault (TFault) is provided. TX_Fault is a module output contact that when high, indicates that the module transmitter has detected a fault condition related to laser operation or safety. The TX_Fault output contact is an open drain/collector and shall be pulled up to the Vcc_Host in the host with a resistor in the range 4.7-10 kΩ. TX_Disable is a module input contact. When TX_Disable is asserted high or left open, the SFP+ module transmitter output shall be turned off. This contact shall be pulled up to VccT with a 4.7 kΩ to 10 kΩ resistor

The receiver converts 8.5Gbit/s serial optical data into serial PECL/CML electrical data. An open collector compatible Loss of Signal is provided. Rx_LOS when high indicates an optical signal level below that specified in the relevant standard. The Rx_LOS contact is an open drain/collector output and shall be pulled up to Vcc_Host in the host with a resistor in the range 4.7-10 kΩ, or with an active termination. Power supply filtering is recommended for both the transmitter and receiver. The Rx_LOS signal is intended as a preliminary indication to the system in which the SFP+ is installed that the received signal strength is below the specified range. Such an indication typically points to non-installed cables, broken cables, or a disabled, failing or a powered off transmitter at the far end of the cable.

Absolute maximum rating

These values represent the damage threshold of the module. Stress in excess of any of the individual Absolute Maximum Ratings can cause immediate catastrophic damage to the module even if all other parameters are within Recommended Operating Conditions.

Parameters	Symbol	Min.	Max.	Unit
Power Supply Voltage	V _{CC}	0	+3.6	V
Storage Temperature	T _c	-40	+85	°C
Operating Case Temperature	T _c	-40	+85	°C
Relative Humidity	RH	5	95	%
RX Input Average Power	P _{max}	-	0	dBm

Recommended operating environment

Recommended Operating Environment specifies parameters for which the electrical and optical characteristics hold unless otherwise noted.

Parameter	Symbol	Min.	Typical	Max	Unit
Power Supply Voltage	V _{CC}	3.135	3.300	3.465	V
Operating Case Temperature	T _c	-40	25	85	°C

Low Speed Characteristics

Parameter	Symbol	Min.	Typical	Max	Unit
Power Consumption				0.8	W
TX_Fault,RX_LOS	VOL	0		0.4	V
	VOH	Host_Vcc-0.5		Host_Vcc+0.3	V
TX_DIS	VIL	-0.3		0.8	V
	VIH	2.0		VCCT+0.3	V
RS0,RS1	VIL	-0.3		0.8	V
	VIH	2.0		VCCT+0.3	V

Optical characteristics

The following optical characteristics are defined over the Recommended Operating Environment unless otherwise specified.

Parameter	Symbol	Min.	Typical	Max	Unit	Notes
Transmitter						
Center Wavelength	λ_t	840	850	860	nm	
RMS spectral width	P_m	-	-	Note 1	nm	
Average Optical Power	P_{avg}	-6.5	-	-1	dBm	2
Extinction Ratio	ER	3.5	-	-	dB	3
Transmitter Dispersion Penalty	TDP	-	-	3.9	dB	
Relative Intensity Noise	R_{in}	-	-	-128	dB/Hz	12dB reflection
Optical Return Loss Tolerance		-	-	12	dB	
Receiver						
Center Wavelength	λ_r	840	850	860	nm	
Receiver Sensitivity	P_{sens}	-	-	-11.1	dBm	4
Stressed Sensitivity in OMA		-	-	-7.5	dBm	4
Los function	Los	-30	-	-12	dBm	
Overload	P_{in}	-	-	-1.0	dBm	4
Receiver Reflectance		-	-	-12	dB	

Note:

1. Trade-offs are available between spectral width, center wavelength and minimum OMA, as shown in table 6.
2. The optical power is launched into MMF
3. Measured with a PRBS $2^{31}-1$ test pattern @8.5Gbps
4. Measured with a PRBS $2^{31}-1$ test pattern @8.5Gbps, BER $\leq 10^{-12}$.

Center Wavelength (nm)	RMS Spectral width (nm)								
	Up to 0.05	0.05 to 0.1	0.1 to 0.15	0.15 to 0.2	0.2 to 0.25	0.25 to 0.3	0.3 to 0.35	0.35 to 0.4	0.4 to 0.45
840 to 842	-4.2	-4.2	-4.1	-4.1	-3.9	-3.8	-3.5	-3.2	-2.8
842 to 844	-4.2	-4.2	-4.2	-4.1	-3.9	-3.8	-3.6	-3.3	-2.9
844 to 846	-4.2	-4.2	-4.2	-4.1	-4.0	-3.8	-3.6	-3.3	-2.9
846 to 848	-4.3	-4.2	-4.2	-4.1	-4.0	-3.8	-3.6	-3.3	-2.9
848 to 850	-4.3	-4.2	-4.2	-4.1	-4.0	-3.8	-3.6	-3.3	-3.0
850 to 852	-4.3	-4.2	-4.2	-4.1	-4.0	-3.8	-3.6	-3.4	-3.0
852 to 854	-4.3	-4.2	-4.2	-4.1	-4.0	-3.9	-3.7	-3.4	-3.1
854 to 856	-4.3	-4.3	-4.2	-4.1	-4.0	-3.9	-3.7	-3.4	-3.1
856 to 858	-4.3	-4.3	-4.2	-4.1	-4.0	-3.9	-3.7	-3.5	-3.1
858 to 860	-4.3	-4.3	-4.2	-4.2	-4.1	-3.9	-3.7	-3.5	-3.2

Electrical characteristics

The following electrical characteristics are defined over the Recommended Operating Environment



unless otherwise specified.

Parameter	Symbol	Min.	Typical	Max	Unit	Notes
Data Rate		-	-	8.5	Gbps	
Power Consumption		-	-	800	mW	
Transmitter						
Single Ended Output Voltage Tolerance		-0.3	-	4.0	V	
C common mode voltage tolerance		15	-	-	mV	
Tx Input Diff Voltage	VI	400		1600	mV	
Tx Fault	VoL	-0.3		0.4	V	At 0.7mA
Data Dependent Input Jitter	DDJ			0.10	UI	
Data Input Total Jitter	TJ			0.28	UI	
Receiver						
Single Ended Output Voltage Tolerance		-0.3	-	4.0	V	
Rx Output Diff Voltage	Vo	300		850	mV	
Rx Output Rise and Fall Time	Tr/Tf	30			ps	20% to 80%
Total Jitter	TJ			0.70	UI	
Deterministic Jitter	DJ			0.42	UI	

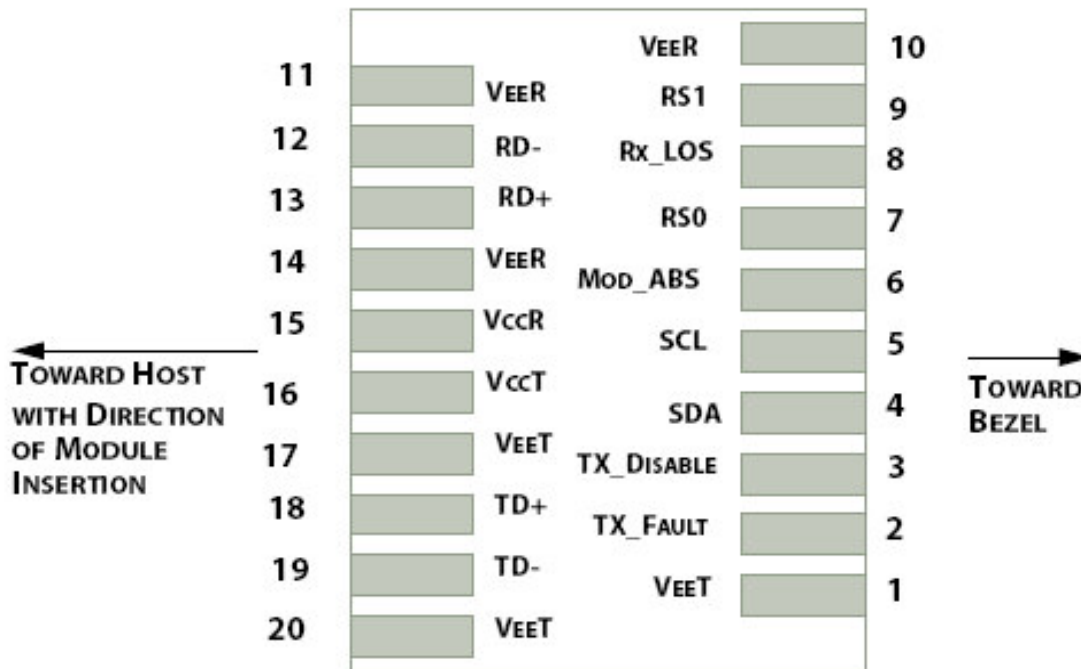

Figure 1: Interface to Host PCB

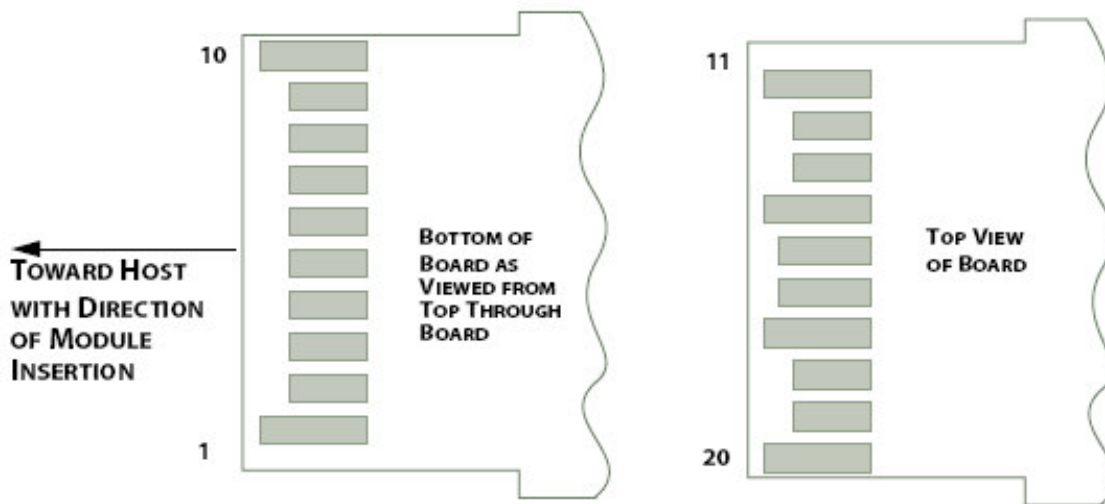

Figure 2: Module Contact Assignment

Pin definition



Pin	Symbol	Name/Description
1	VEET [1]	Transmitter Ground
2	Tx_FAULT [2]	Transmitter Fault
3	Tx_DIS [3]	Transmitter Disable. Laser output disabled on high or open
4	SDA [2]	2-wire Serial Interface Data Line
5	SCL [2]	2-wire Serial Interface Clock Line
6	MOD_ABS [4]	Module Absent. Grounded within the module
7	RS0 [5]	Rate Select 0
8	RX_LOS [2]	Loss of Signal indication. Logic 0 indicates normal operation
9	RS1 [5]	Rate Select 1
10	VEER [1]	Receiver Ground
11	VEER [1]	Receiver Ground
12	RD-	Receiver Inverted DATA out. AC Coupled
13	RD+	Receiver DATA out. AC Coupled
14	VEER [1]	Receiver Ground
15	VCCR	Receiver Power Supply
16	VCCT	Transmitter Power Supply
17	VEET [1]	Transmitter Ground
18	TD+	Transmitter DATA in. AC Coupled
19	TD-	Transmitter Inverted DATA in. AC Coupled
20	VEET [1]	Transmitter Ground

Notes:

- [1] Module circuit ground is isolated from module chassis ground within the module.
- [2].should be pulled up with 4.7k – 10k ohms on host board to a voltage between 3.15V and 3.6V.
- [3]Tx_Disable is an input contact with a 4.7 kΩ to 10 kΩ pullup to VccT inside the module.
- [4]Mod_ABS is connected to VeeT or VeeR in the SFP+ module. The host may pull this contact up to Vcc_Host with a resistor in the range 4.7 kΩ to 10 kΩ. Mod_ABS is asserted “High” when the SFP+ module is physically absent from a host slot.
- [5] RS0 and RS1 are module inputs and are pulled low to VeeT with > 30 kΩ resistors in the module.

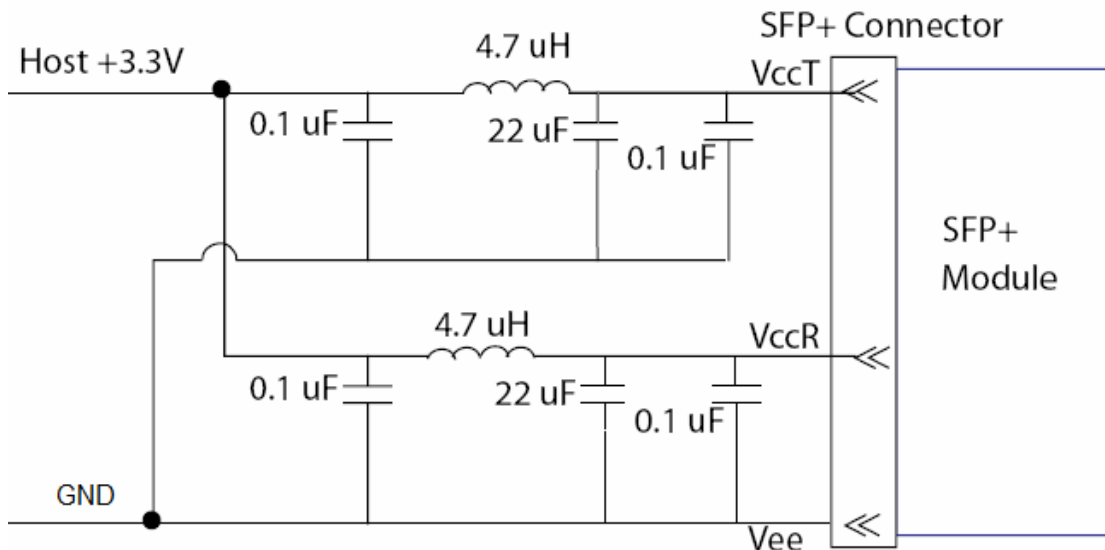

Figure3. Host Board Power Supply Filters Circuit

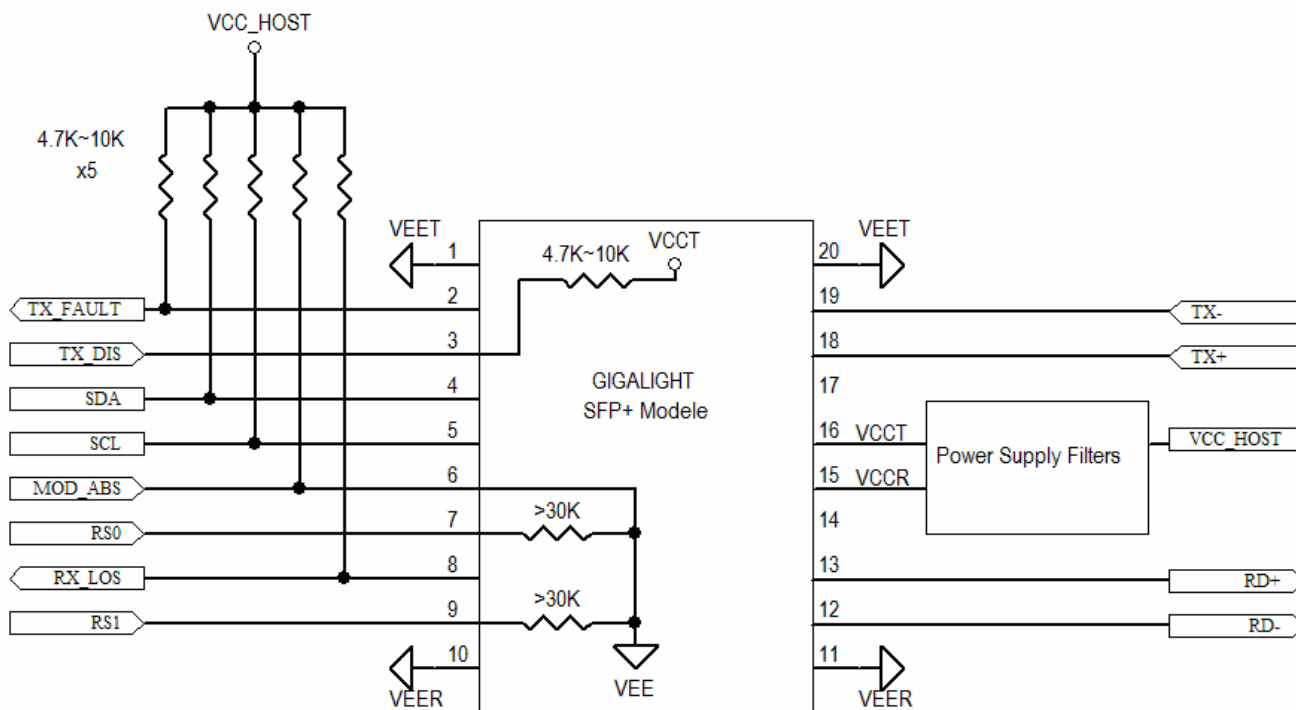

Figure4. Host-Module Interface

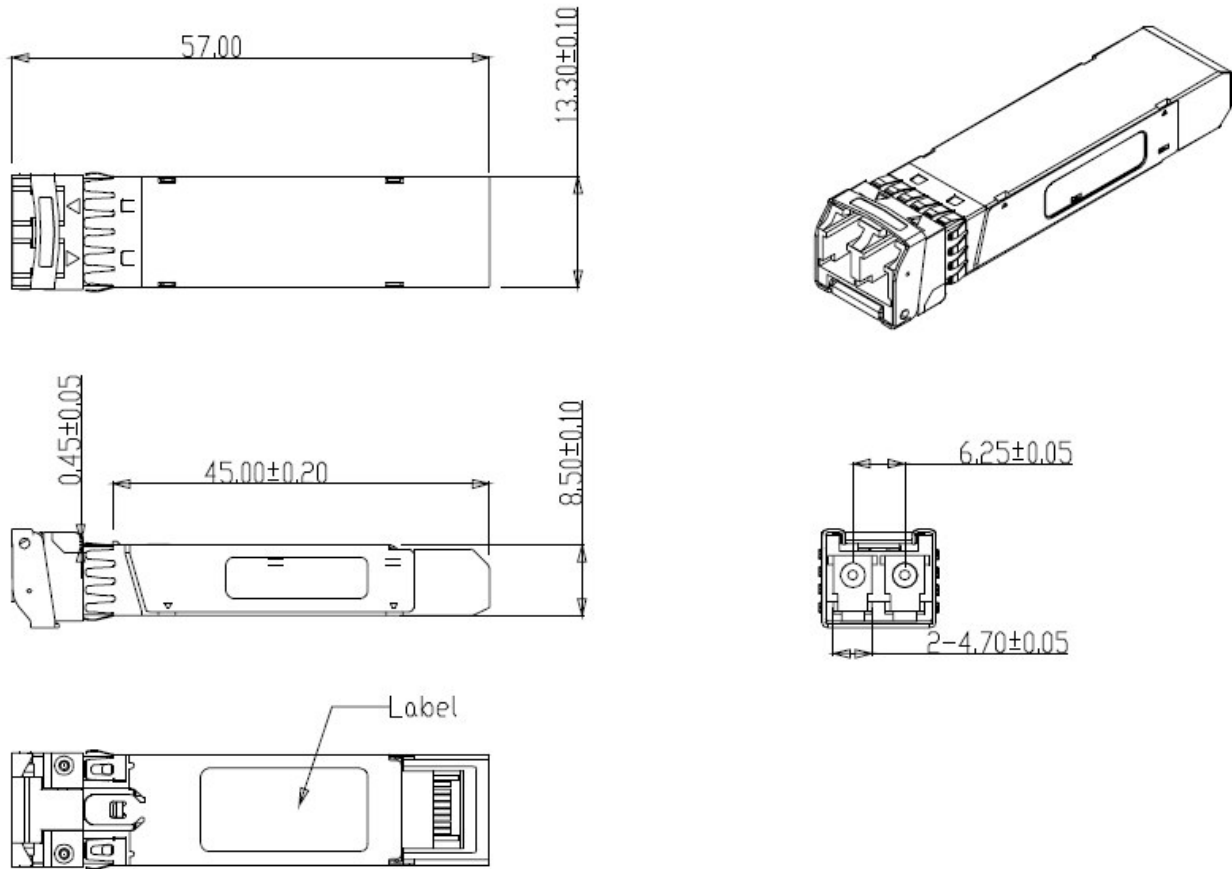

Figure5. Mechanical Specifications

Regulatory Compliance

FIBERER SFP+ transceiver is designed to be Class I Laser safety compliant and is certified per the following standards:

Feature	Agency	Standard	Certificate / Comments
Laser Safety	FDA	CDRH 21 CFR 1040 annd Laser Notice No. 50	1120292-000
Product Safety	UL	UL and CUL EN60950-2:2007	E347511
Environmental protection	SGS	RoHS Directive 2002/95/EC	GZ1001008918/CHEM
EMC	WALTEK	EN 55022:2006+A1:2007 EN 55024:1998+A1+A2:2003	WT10093759-D-E-E



Ordering information

Part Number	Product Description
FPP-858G-SRC	850nm, 8.5Gbps, SFP+ 300m, -0°C ~ +70°C
FPP-858G-SRT	850nm, 8.5Gbps, SFP+ 300m, -40°C ~ +85°C

References

1. "Specifications for Enhanced Small Form Factor Pluggable Module SFP+", SFFPP-8431, Rev 4.1, July 6, 2009.
2. "Improved Pluggable Formfactor", SFFPP-8432, Rev 4.2, Apr 18, 2007
3. IEEE802.3ae – 2002
4. "Diagnostic Monitoring Interface for Optical Transceivers" SFFPP-8472, Rev 10.3, Dec 1, 2007

Important Notice

Performance figures, data and any illustrative material provided in this data sheet are typical and must be specifically confirmed in writing by **FIBERER** before they become applicable to any particular order or contract. In accordance with the **FIBERER** policy of continuous improvement specifications may change without notice.

The publication of information in this data sheet does not imply freedom from patent or other protective rights of **FIBERER** or others. Further details are available from any **FIBERER** sales representative.

Copyright@ Fiberer Global Tech Ltd.

Our Spiritual Mission

To facilitate User's network and testing systems more successful, let the world more beautiful by our high quality and stability of products and VIP service.

Production Capacity

The quantity of our staff is more than 2,800 and the workshop area is 6,000 square meters. We have a 10,000 level of purifications production workshop about 3000 square meters, and the production capacity is above 5000pcs/week on fiber-optic modules and components.

Email: engineer@fiberer.com

Website: <http://www.sfp-module.com>